



S-60-M2 MINI TOWER mk2 7.5m/650kg

INSTRUCTION MANUAL

FOREWORD

This manual is intended for sound-, lighting- and rigging technicians. The set-up and operation of the ALC Truss tower systems demands reading and complete understanding of the instruction manual.

It gives practical directives how to handle the ALC Truss products in general in a safe and efficient way.

Only by carefully following the step-by-step actions during preparation, set-up and operation of the systems, a safe and successful production can be guaranteed.

TABLE OF CONTENTS

	page
FOREWORD	2
TABLE OF CONTENTS	2
INSTALLATION	3
EQUIPMENT HANDLING	4
GENERAL SAFETY INSTRUCTIONS	6
GENERAL CONDITIONS OF SETUP	7
SET-UP	8
CONTACT	17

INSTALLATION

a) Package

A complete 7,5m high **MINI TOWER mk2** system consists of three (3) ALC Truss S-60-24 Stackable Triangle Trusses , transported by means of a dolly system and a dedicated MINI TOWER mk2 Base system, which contains the necessary truss pins, hammers, screw jacks, nuts and bolts, MINI TOWER mk2 Top, Cantilever and the optional Platform and Roof. The system is designed to take a minimum of warehouse and transport space: L x W x H in mm. Pile of 3 trusses = 600 x 2450 x 850 Base 2300 x 340 x 1430

b) Handling and set-up time

The **MINI TOWER mk2** system takes about 10 minutes to set-up by **two persons**.

c) Contents of the standard package (items with * are optionally available)

CODE	DESCRIPTION	#
S-60-24	Stackable triangle truss - 60cm x 60cm - 2,4m section	3
S-60-DL	DoLLy	2
S-60-TP	Truss Pin including safety system	12
S-60-HM	HaMmer / Drive-out pin	2
S-60-M2B	MINI TOWER mk2 Base section	1
S-60-M2C	MINI TOWER mk2 Cantilever System	1
S-60-M2T	MINI TOWER mk2 Top section incl. 4 chain wheels	1
S-60-SP	35cm Screw-Jack (Foot Spindle)	5
S-60-M2P	MINI TOWER mk2 Platform *	1
S-60-M2R	MINI TOWER mk2 Roof *	1

d) Chain hoist

The use of each **MINI TOWER mk2** requires minimum one (1) electric chain hoist with a capacity of 1/2 ton. This chain hoist, with a minimum chain length of 16m, must be conform with the 98/37/EC directives, specific national regulations for lifting equipments as well as maintenance procedures. The chain hoists are not included in the package.

EQUIPMENT HANDLING

DO'S

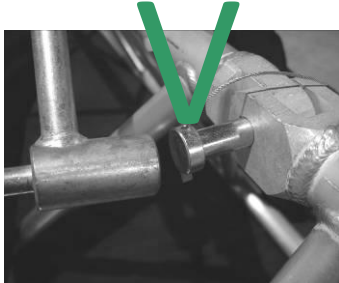

DON'T'S

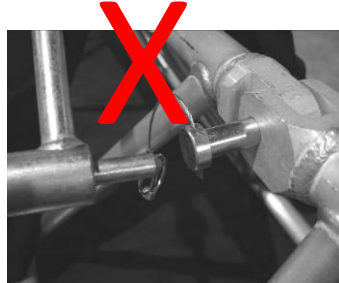

Use the right side of the hammer (S-60-HM) to connect the truss elements.

Assemble the trusses with the truss pins, preferably from the inside out.

Always use 2 hammers to disable a truss pin.

PIN SAFETY PROCEDURE



When connecting two truss elements by a truss pin, make sure the cable (with the safety at the end) is perpendicular to the truss length. This makes the connection of the safety to the pin easier, since the cable length itself is kept at a minimum.



To separate the trusses sections from a package, first ensure that the package is upright with the 'fork-connections' pointing downwards.



Handling is easiest by two persons, who lift the first section slightly and then remove it from the pile, starting at the bottom. Use the inverse procedure to stack trusses of the same length.

GENERAL SAFETY INSTRUCTIONS

Please take notice of following safety instructions in order to assure a safe preparation, set-up and operation of the **MINI TOWER mk2** system:

- Always wear the appropriate clothing before handling the tower system: We advise you to wear safety gloves, shoes and helmet, that provide basic protection against possible occurring injuries.
- Lifting persons is prohibited, as is climbing people on the structure. The only people allowed to climb the mast or structure are those who charged with loading and attaching it to the mast, or other actions related to the placement of the loading equipment. You may only climb the system if the load has been applied to the structure.
- This manual clearly indicates the possibilities of the tower system and how it should be used. No actions or applications other than those specified in this manual are allowed, as they may result in an unsafe situation that could result in personal or and material damage.
- The installation of the tower system must be carried out by a minimum of two technicians in good physical and mental condition (not under the influence of alcohol, drugs, or any other intoxicating products). While installing the tower, always keep the focus on the product, to give absolute priority to safety (mobiles switched off,...).
- Never leave the tower system unguarded while setting it up. So once the set-up has started, the technicians involved should finish the actions till the tower system is ready for lifting the load, without leaving this place.
- After each installation and operation of the **MINI TOWER mk2** system, each part of the total structure must be inspected on possible damages.
- In any case, ALC-engineering does not take responsibility in any way for any of your actions during the preparations, set-up, operation and the lowering and packing of the tower system.

GENERAL CONDITIONS OF SETUP

Given the above safety instructions, make sure the following both general as environmental conditions are guaranteed:

- As clearly shown on the product label and noted further in the set-up manual, the allowable vertical load is strictly limited to **650kg**.
- Specific requirements with regard to the subsoil or soil structure and pressure capacity must be considered: the direct local soil pressure must, for example, be divided by means of plastic, hardwood or metal distribution plates under the basic construction, when used on sandy soil for example.
- For indoor use, wind forces can be neglected and result in a minimum reaction force in the support points of 300kg (screw jack area of 150mm x 150mm)
- For outdoor use, the maximum reaction force in the supports can be 1.100kg.
- Be aware that when setting up the tower system, you need at least a rectangular space of about 4m wide and 9.0m long. During set-up, make sure this space does not block any important passages or so. Do not allow people to enter this space under any circumstances. Once upright, the tower basis takes about 6.5m² of space. It is advisable to restrict an additional area of 10m² around the tower, for example by fences.
- While preparing and setting up the tower system, make sure only people involved with its set-up are allowed in the neighbourhood of the **MINI TOWER mk2**.
- When using outdoor, wind speeds of up to 75 km/h (8 Beaufort – 20m/s) are allowed, taking into account the following limits for load dimensions.

Maximum horizontal projection surfaces: Front : 4,5m²
Side : 2,0m²

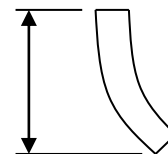

- As soon as the wind speed exceeds this value, the load must be lowered.
- The load can be placed on the base, platform, sub speakers,... with the hoist being minimally loaded to keep the load on the system stable. This way, extra ballast is created on the basis of the structure to guarantee a safe and stable situation in case the wind speeds exceed the maximum operating values.
- When setting up the **MINI TOWER mk2**, when the mast is raised vertically, wind speeds must not exceed 5 Beaufort (40km/h – 11m/s)

SETUP

MINI TOWER MK2 ITEMS:

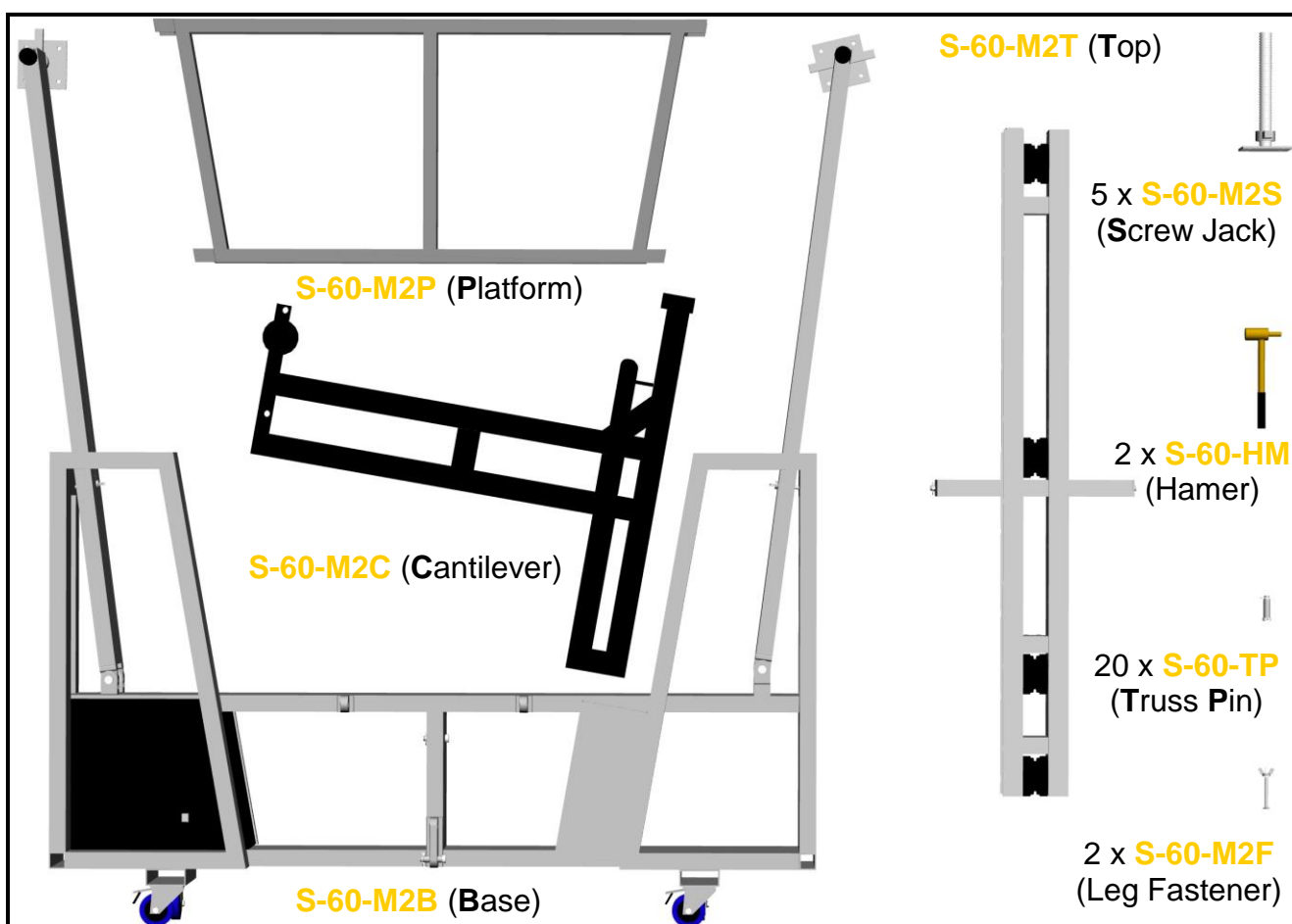

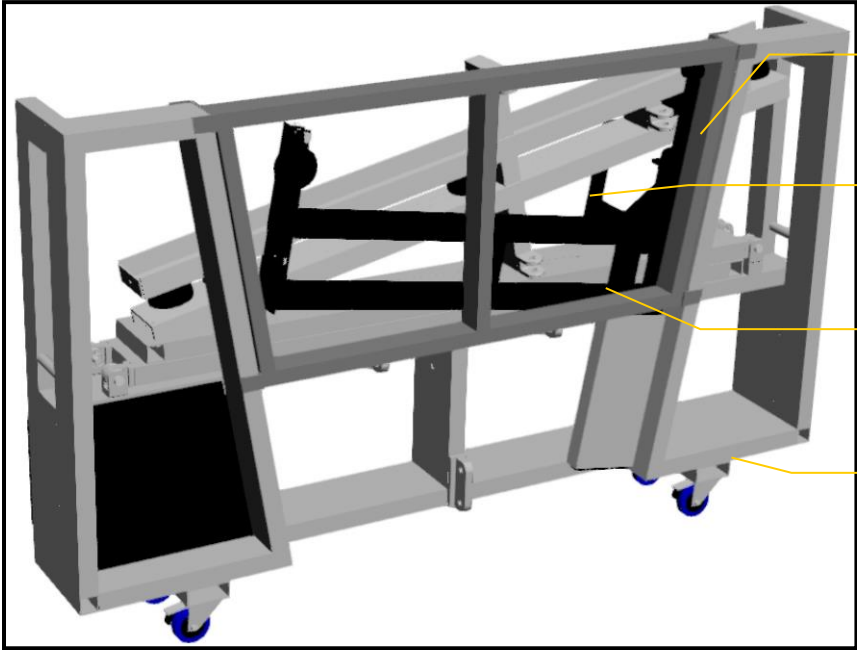

S-60-M2P (Platform)

S-60-M2T (Top)

S-60-M2C (Cantilever)

S-60-M2B (Base)

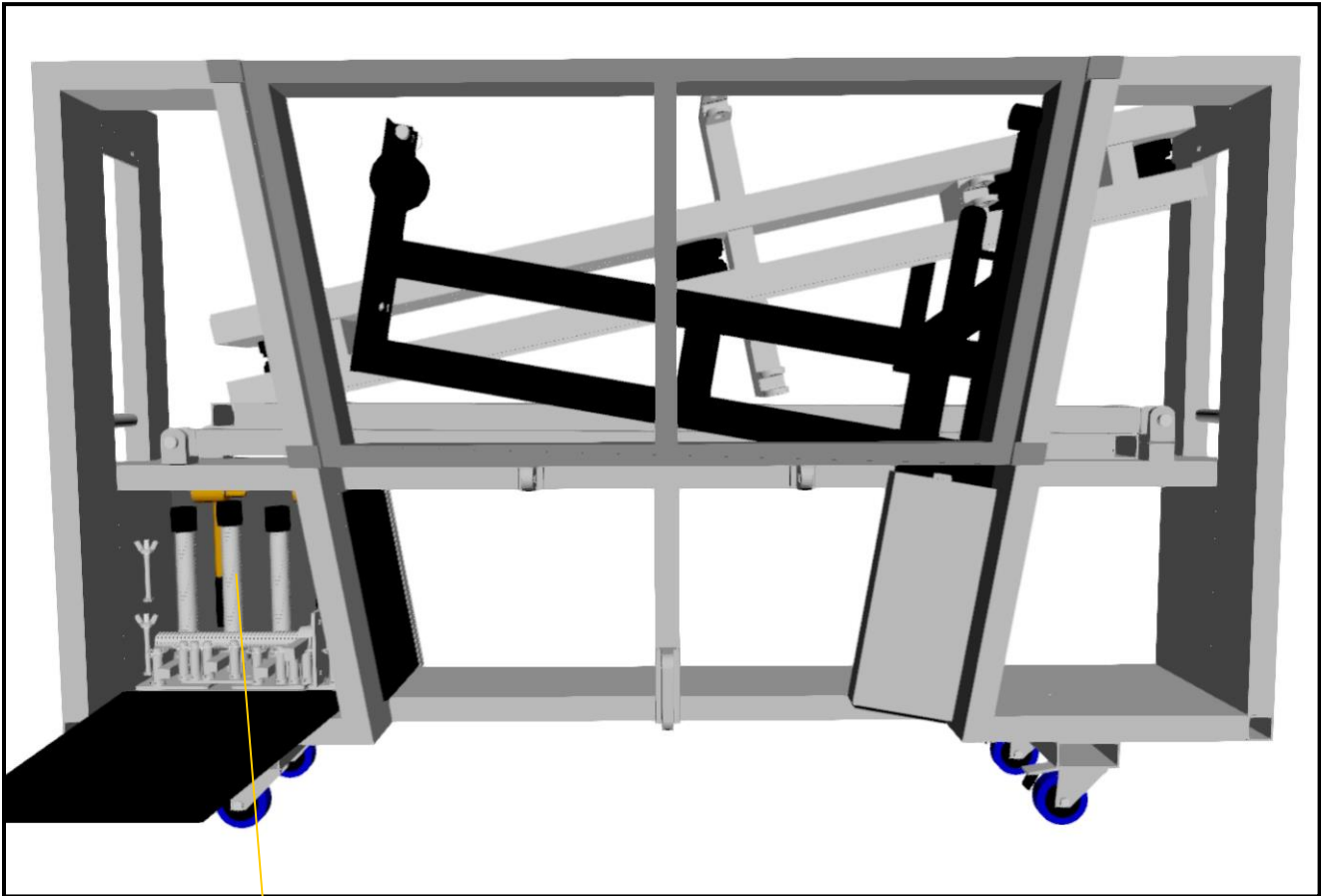

Locker accessories

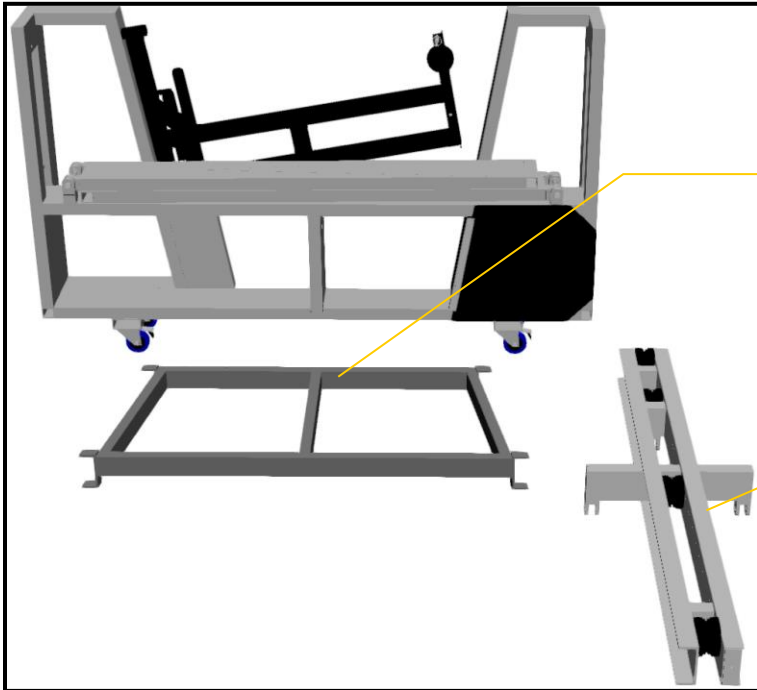

Step 1 :

Unpack **S-60-M2P**
(Platform)

Step 2 :

Unpack **S-60-M2T**
(Top)

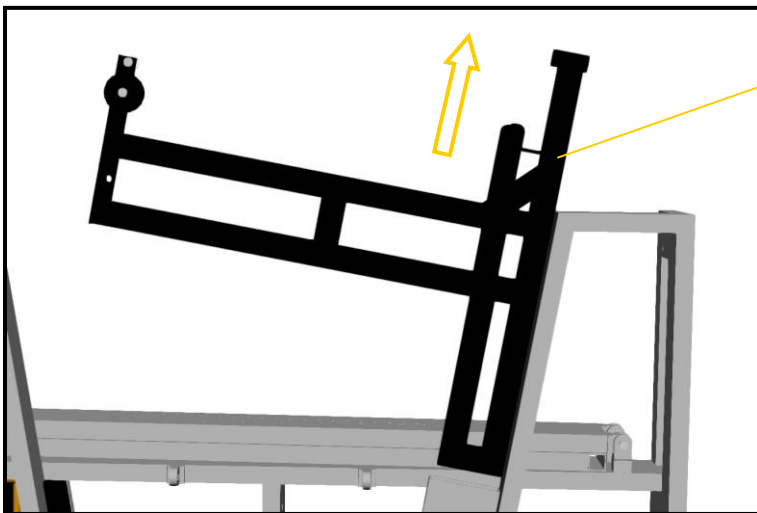

Step 3 :

Pull out **S-60-M2C**
(Cantilever)

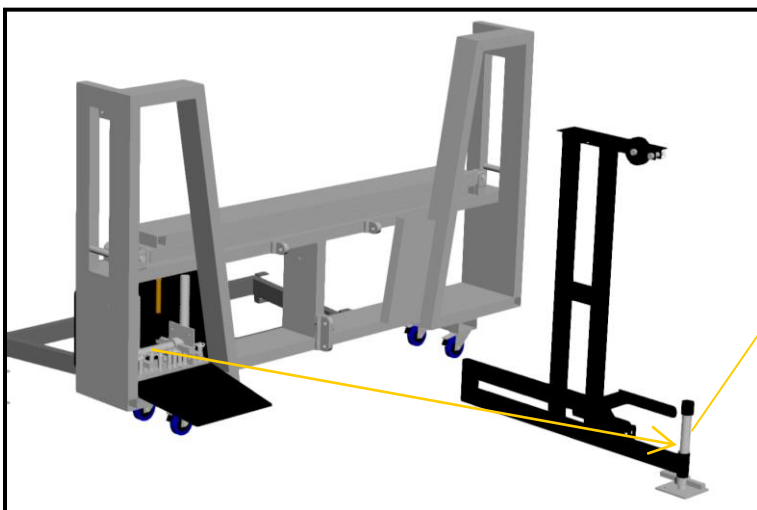

Step 4 :

Assemble **S-60-M2C**
(Cantilever)
+
S-60-M2S (Screw Jack)

Step 5 :

Place the wheels on this side perpendicular to the length of the **S-60-M2B** Base).

Step 6 :

Set the brakes of both wheels on both sides.

Step 7 :

Slide 2 x **S-60-M2S** (Screw Jack) into the designated holes of the **S-60-M2B** (Base).

Step 8 :

Slide 1 x **S-60-M2S** (Screw Jack) in the designated hole of the upper leg of the **S-60-M2B** (Base). Screw the rubber cap onto the Screw Jack.

Step 9 :

Raise the leg.

Step 10 :

Connect with **S-60-M2F** (Leg Fastener)

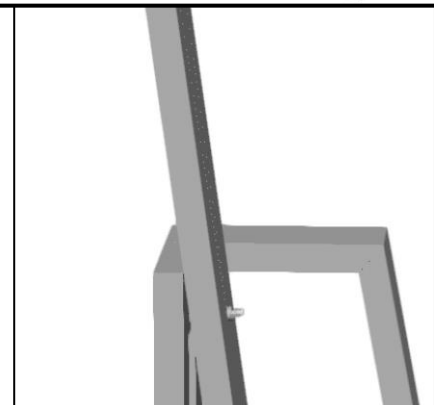
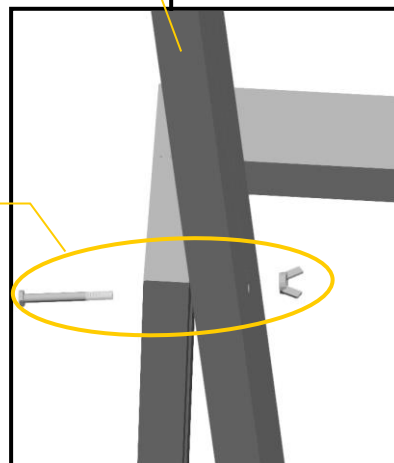
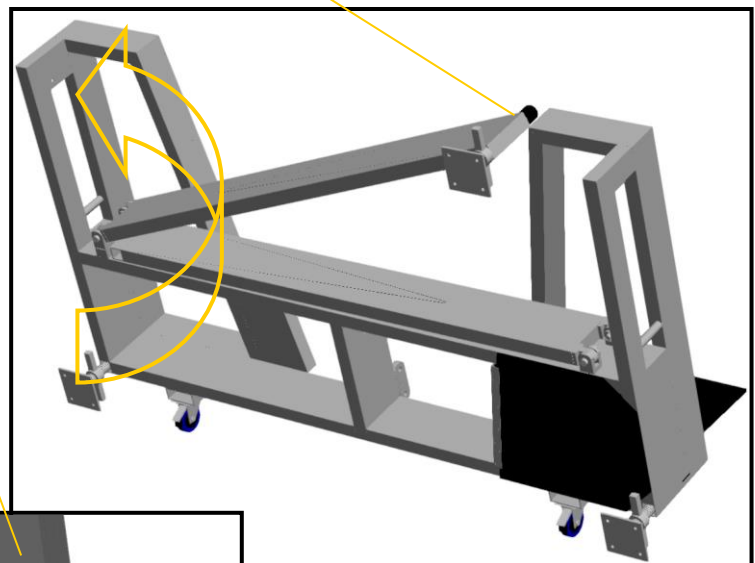
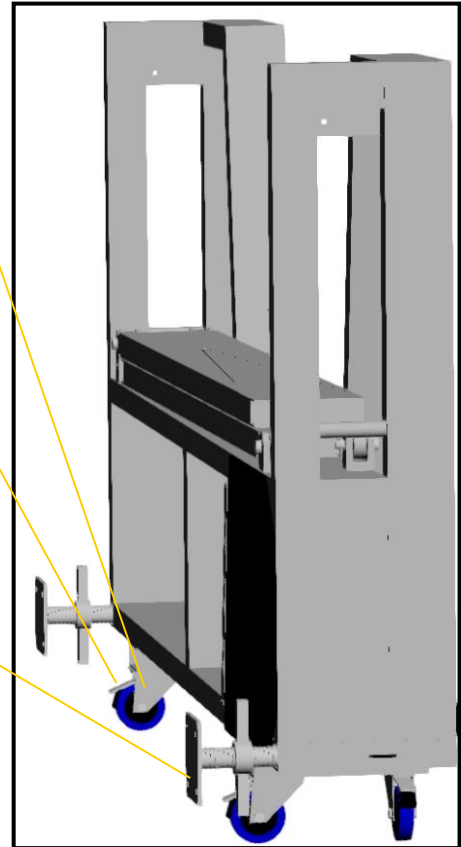

Step 11 :

Treat the second leg exactly like the first leg. Step 8

Step 12 :

Grab the Leg and pull the direction of the arrow until the inserted **S-60-M2S** (screw jack) touches the floor.

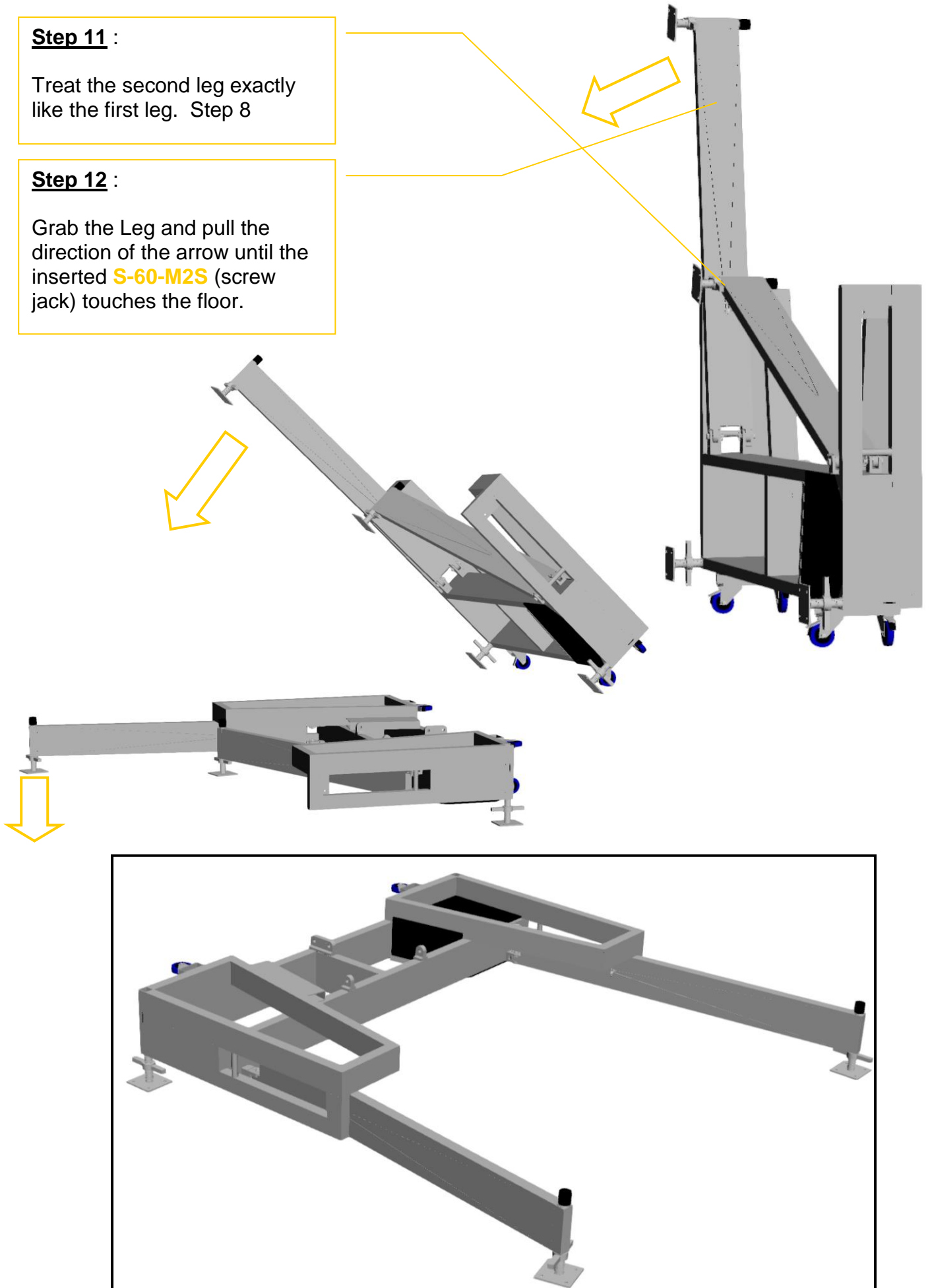

Step 13 :

Connect one (1) Stackable Truss section **S-60-24** with two (2) Truss Pins **S-60-TP** to the Base **S-60-M2B**

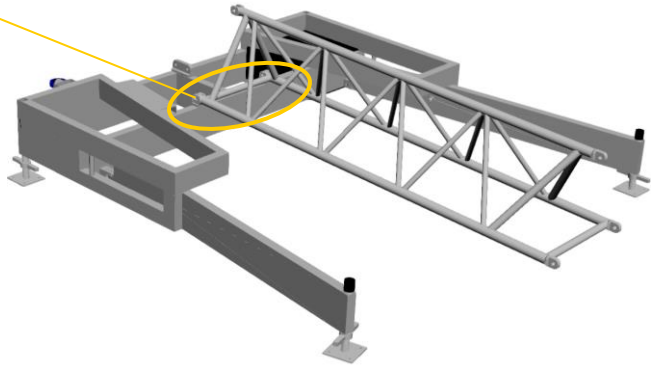

Step 14 :

Connect one (1) Stackable Truss section **S-60-24** with three (3) Truss Pins **S-60-TP** to the first Stackable Truss section **S-60-24**

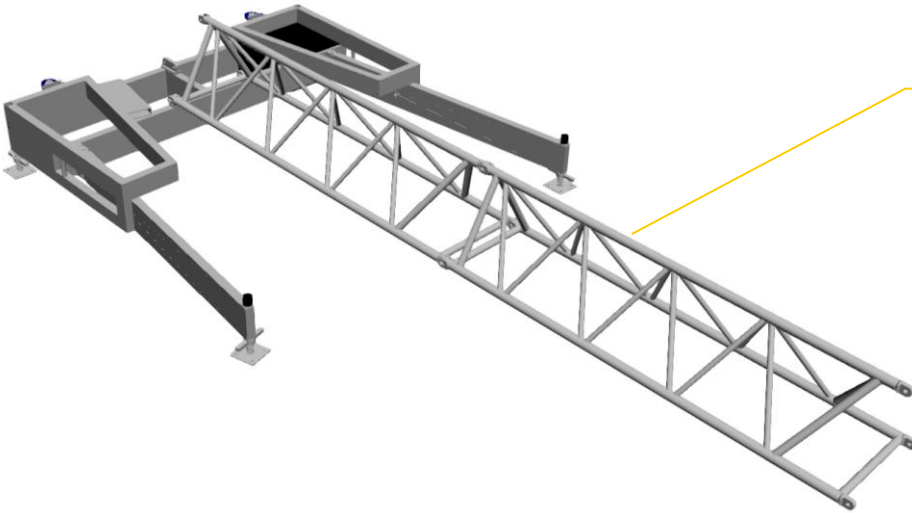

Step 15 :

Connect one (1) Stackable Truss section **S-60-24** with three (3) Truss Pins **S-60-TP** to the previous Stackable Truss section **S-60-24**

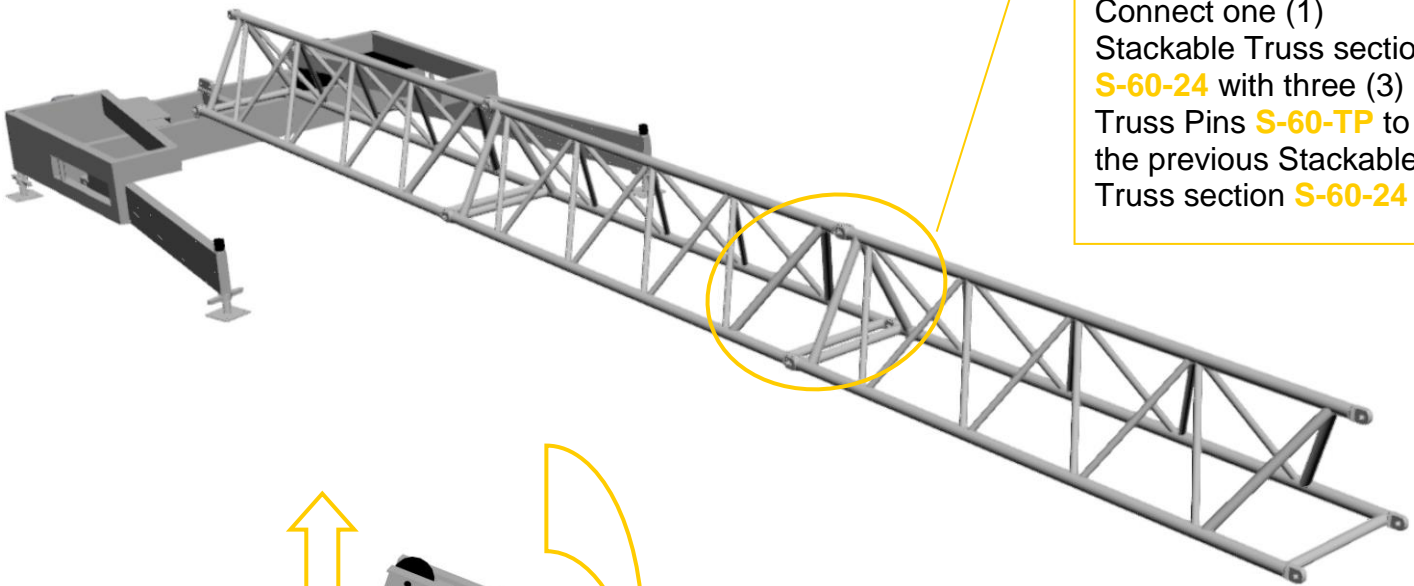

Step 16 :

Connect the Top piece **S-60-M2T** with one (1) Truss Pins **S-60-TP** to Stackable Truss section **S-60-24**

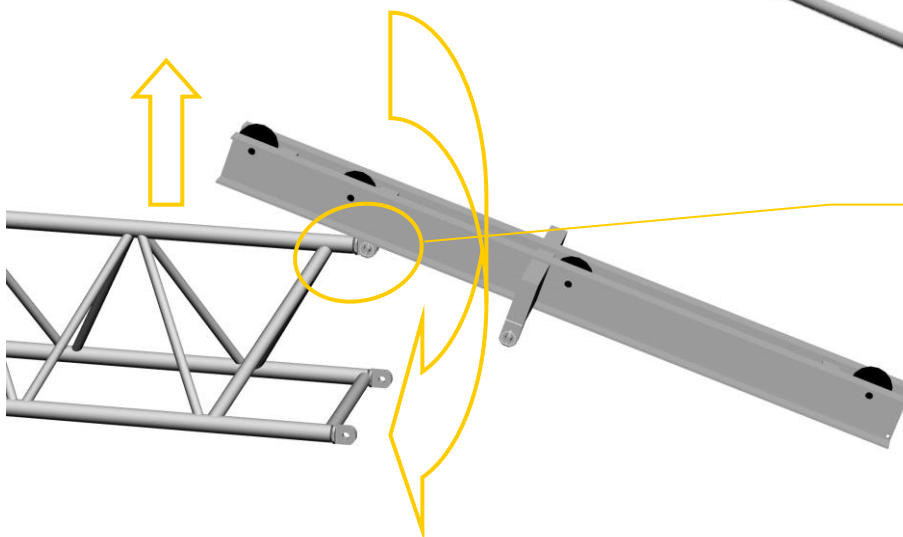

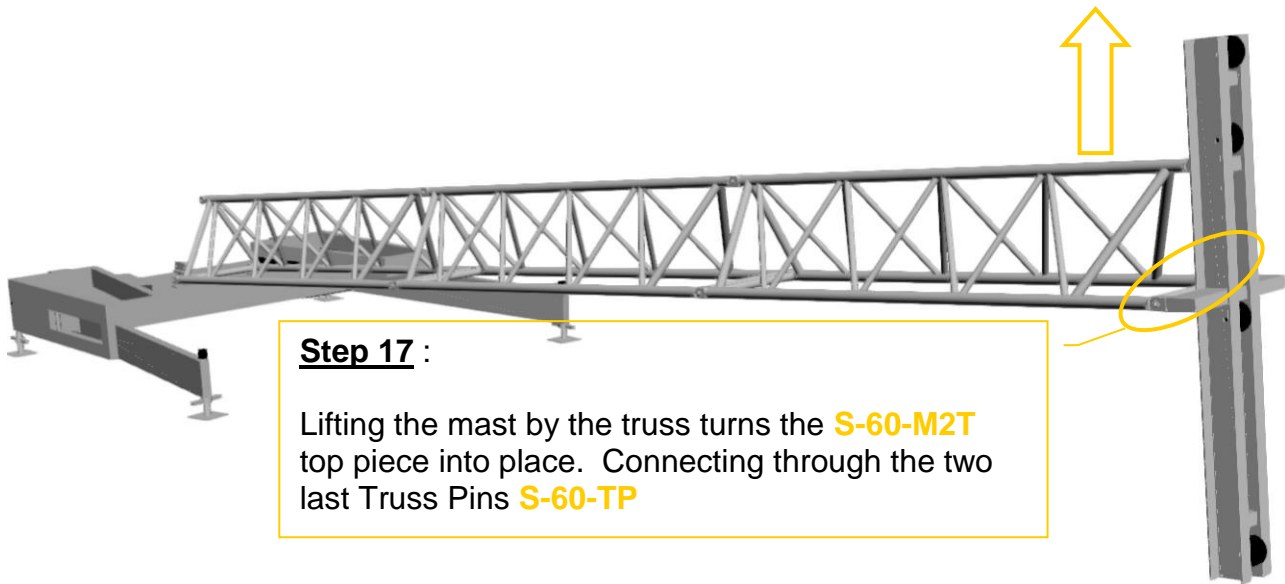

Step 17 :

Lifting the mast by the truss turns the **S-60-M2T** top piece into place. Connecting through the two last Truss Pins **S-60-TP**

Step 18 :

Slide the Cantilever piece **S-60-M2C** into the designated space of the base

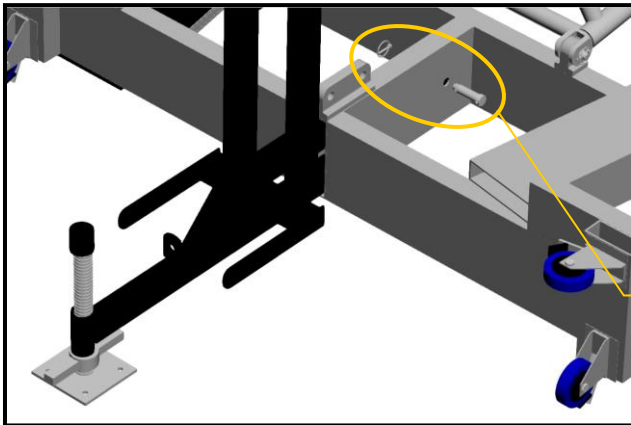
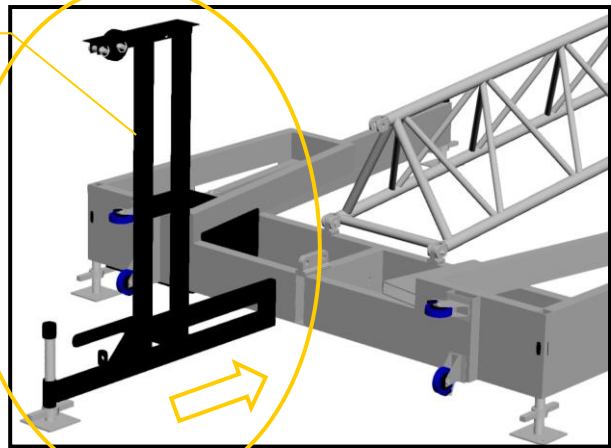

Step 19 :

Secure the position of the Cantilever **S-60-M2C** at the base by means of a truss pin+safety **S-60-TP**.

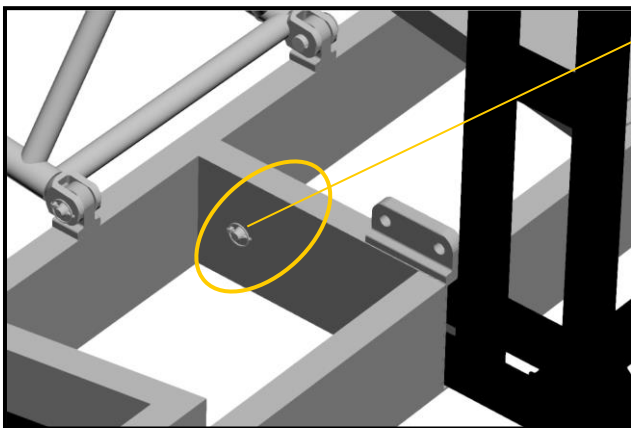

Step 20 :

Place a chain hoist of ½ or 1 ton, in its flight case next to the Cantilever **S-60-M2C**

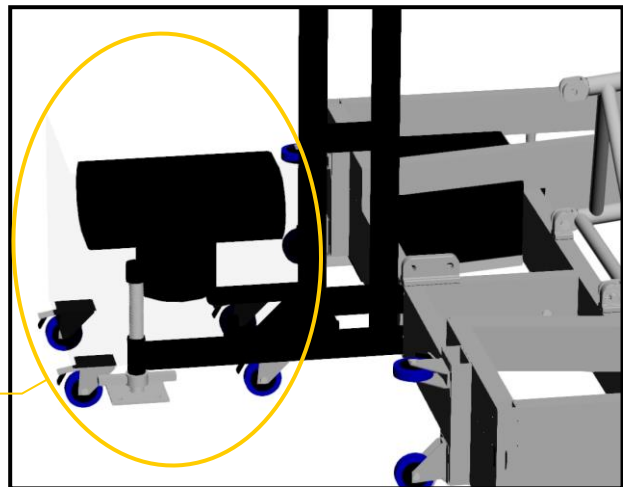

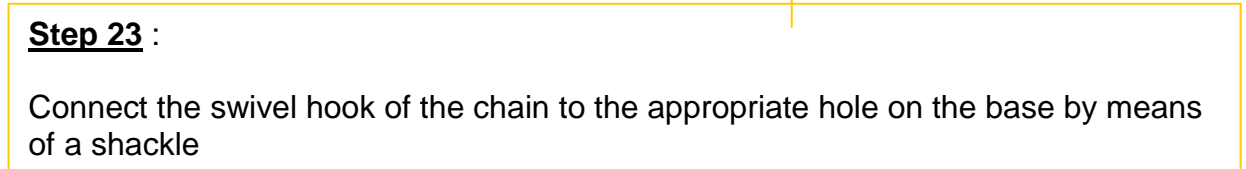
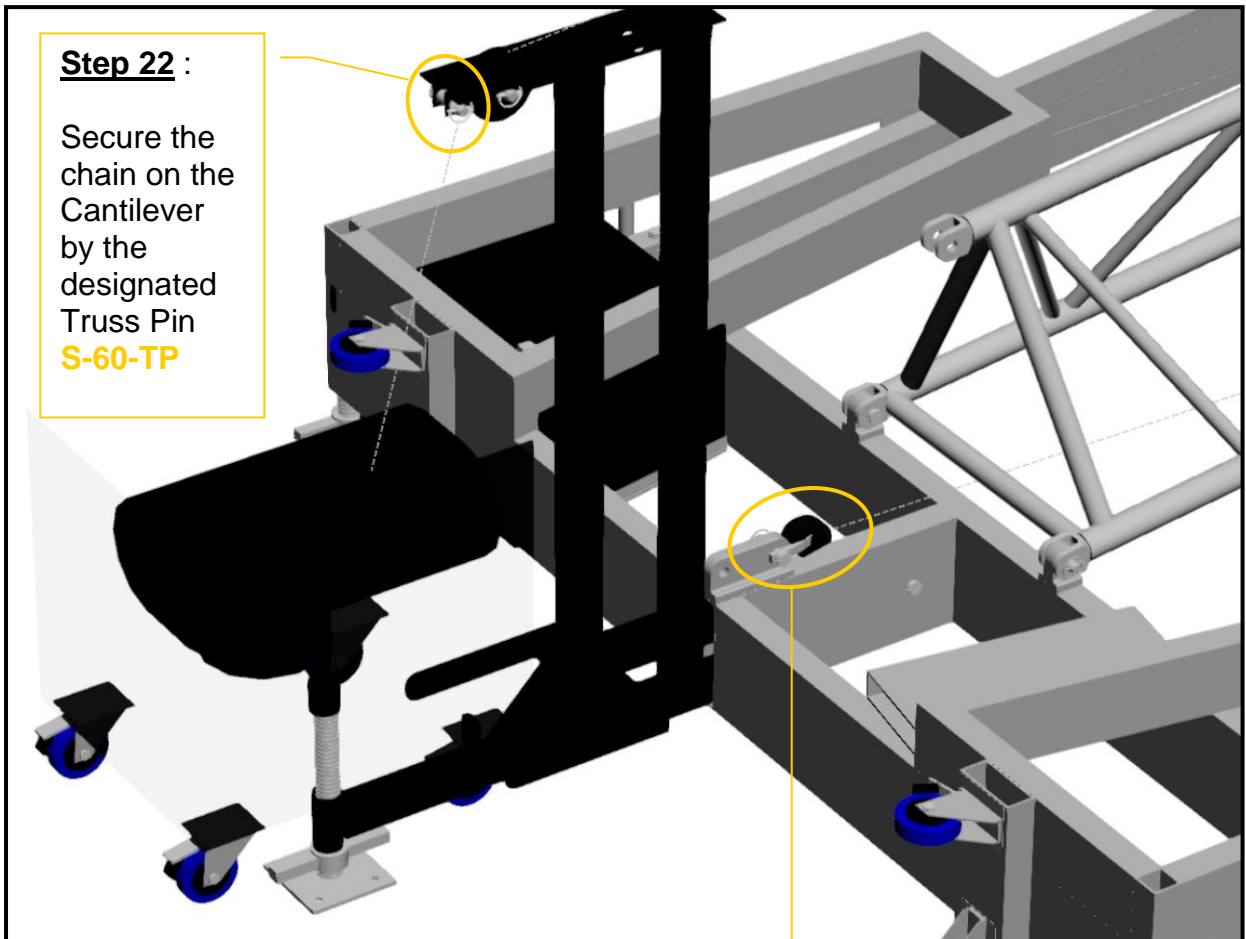
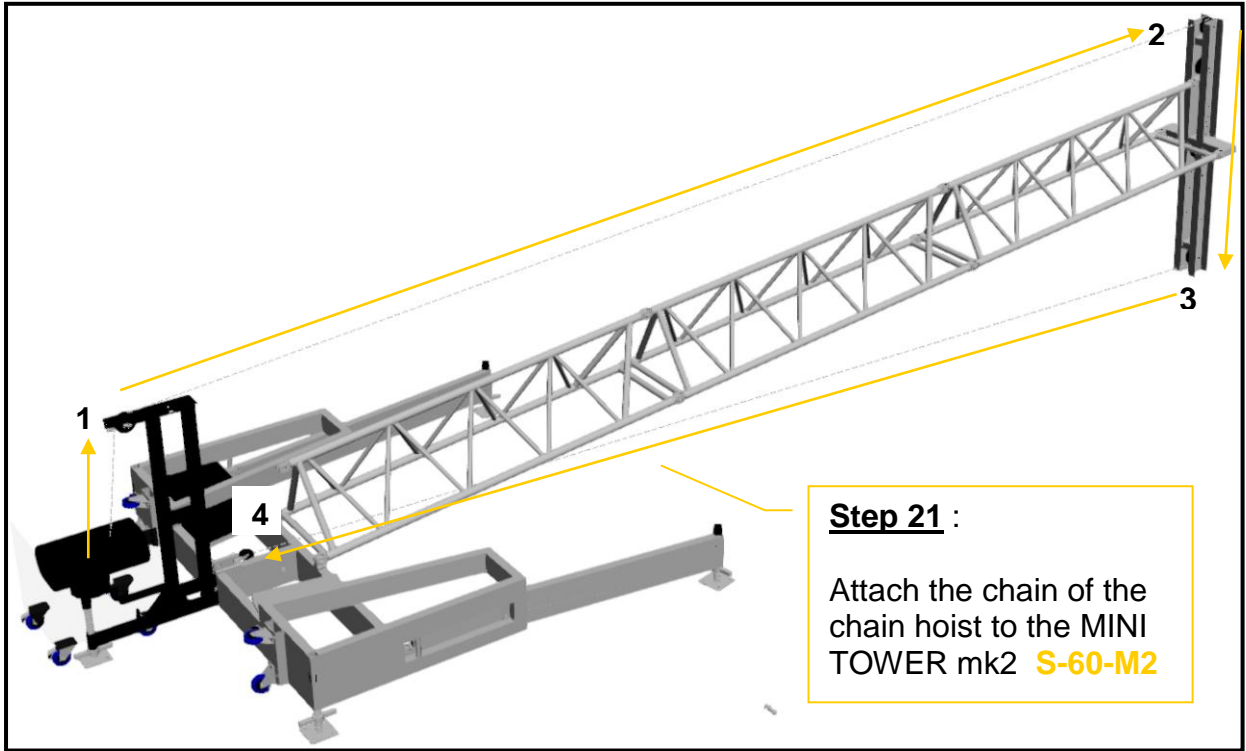

Step 24 :

Let the chain hoist lift out of its case by its own power

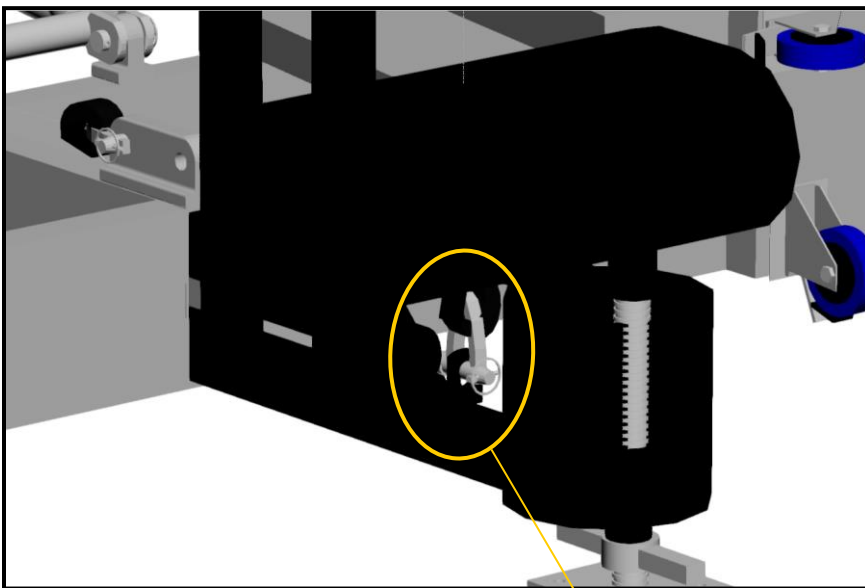
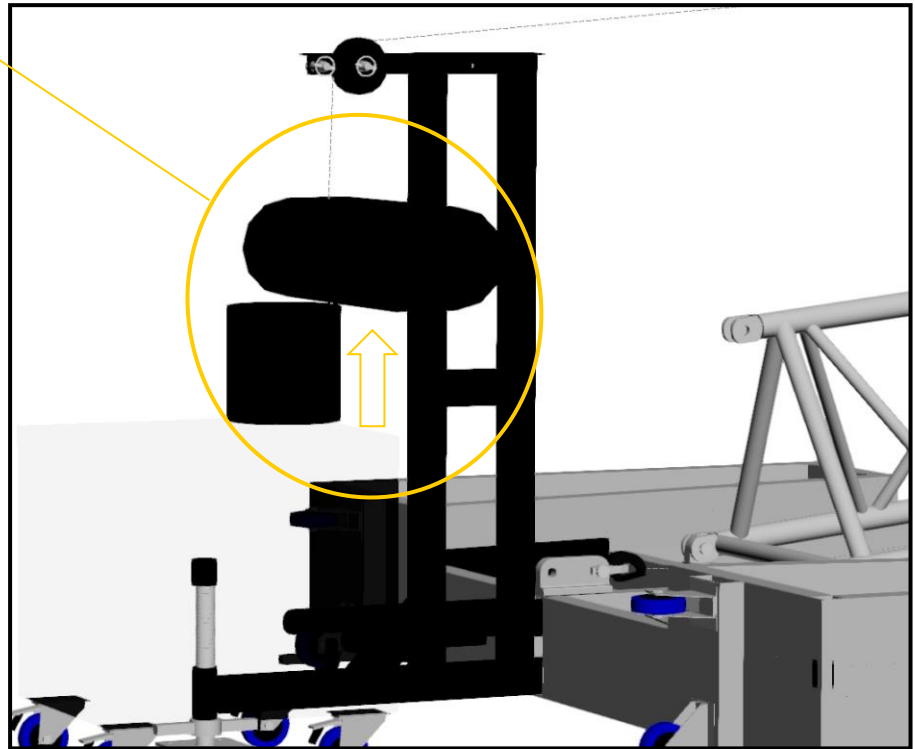

Step 25 :

Lower the chain hoist and connect it by a shackle onto the Cantilever

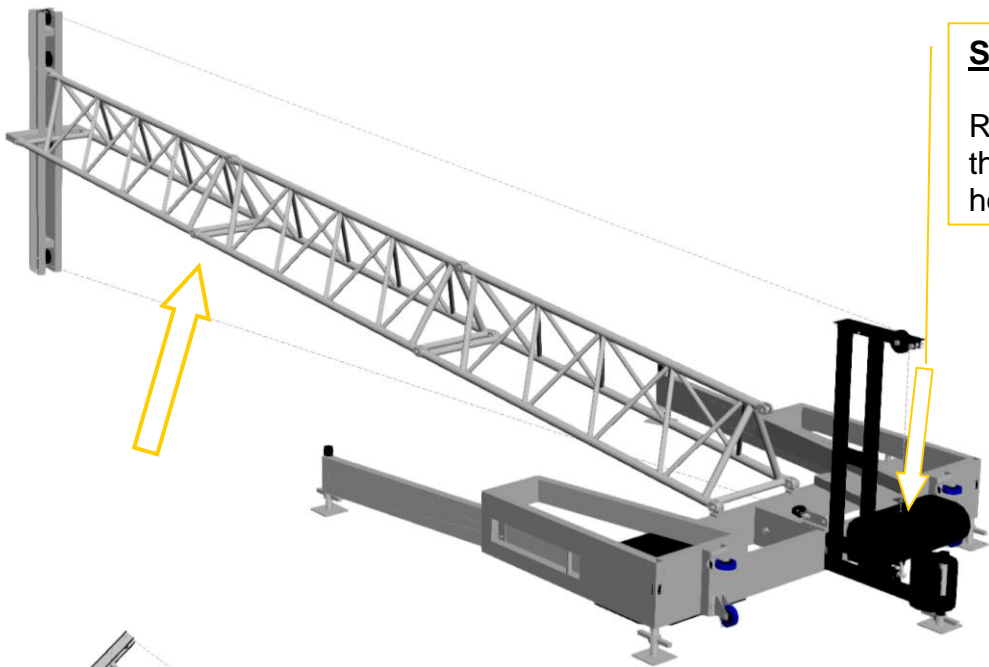

Step 26 :
Raise the mast with the aid of the chain hoist.

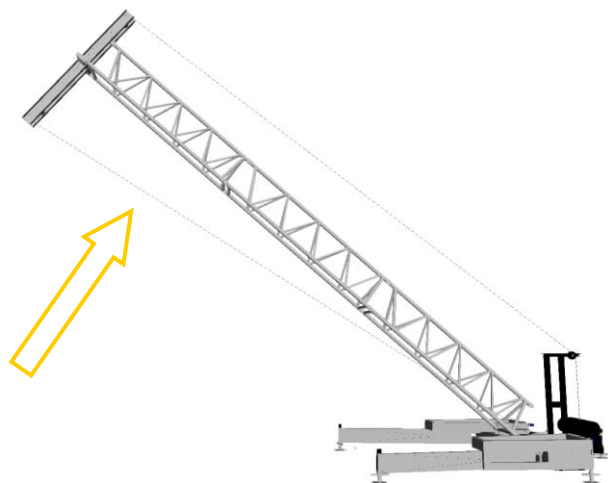

Complete the raising of the mast by stopping the chain hoist just before the mast is completely in vertical position. For a smooth operation, the last part must be done manually !

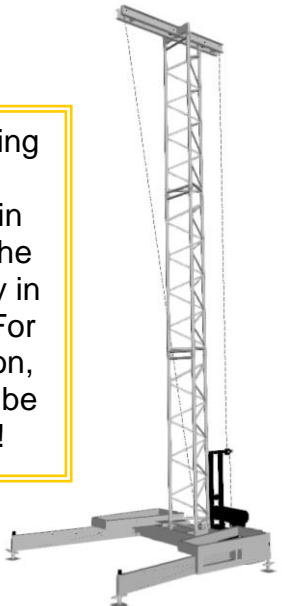

Step 27 :
Attach the mast to the Base by fitting the third Truss Pin **S-60-TP**

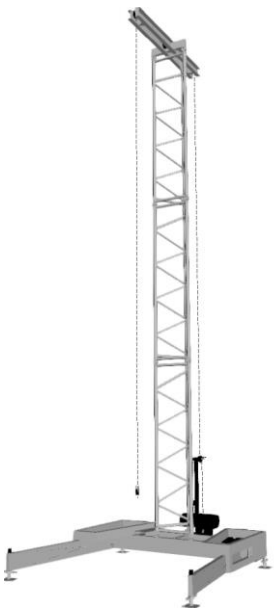
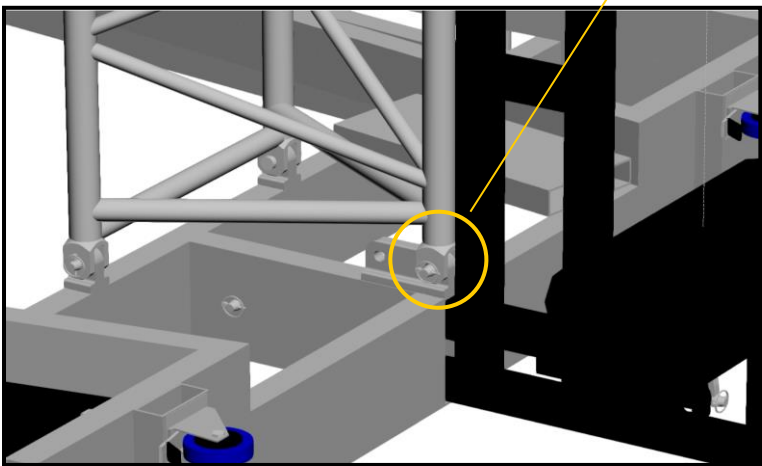

Step 28 :

Level the **MINI TOWER mk2** by adjusting the Screw Jacks **S-60-M2S**

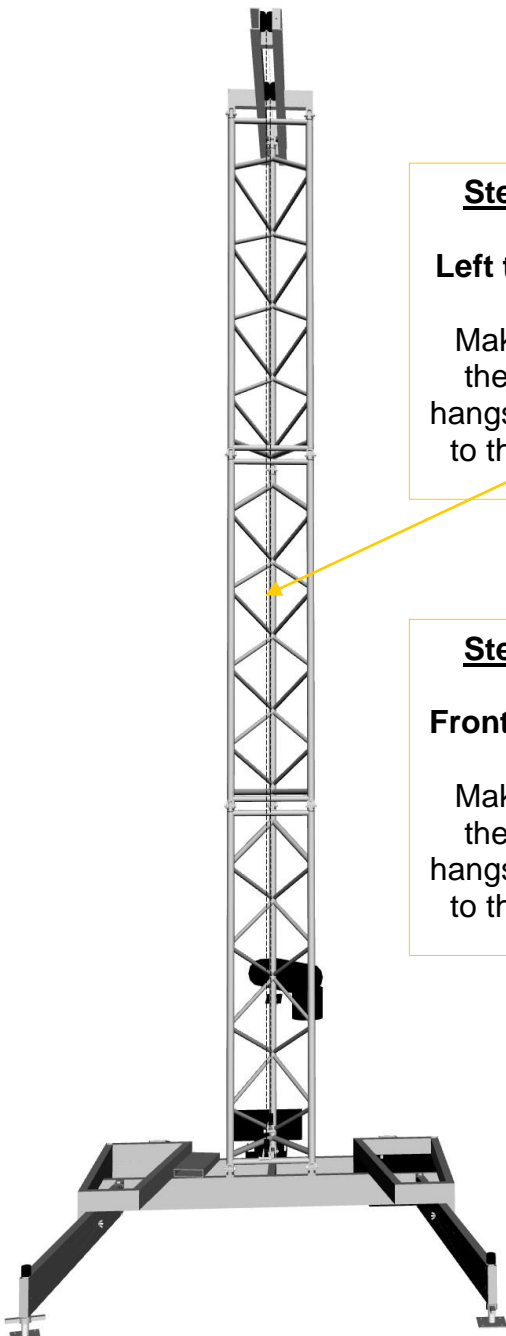

Step 29 :
Left to Right
Make sure the chain hangs parallel to the mast

Step 30 :
Front to Rear
Make sure the chain hangs parallel to the mast

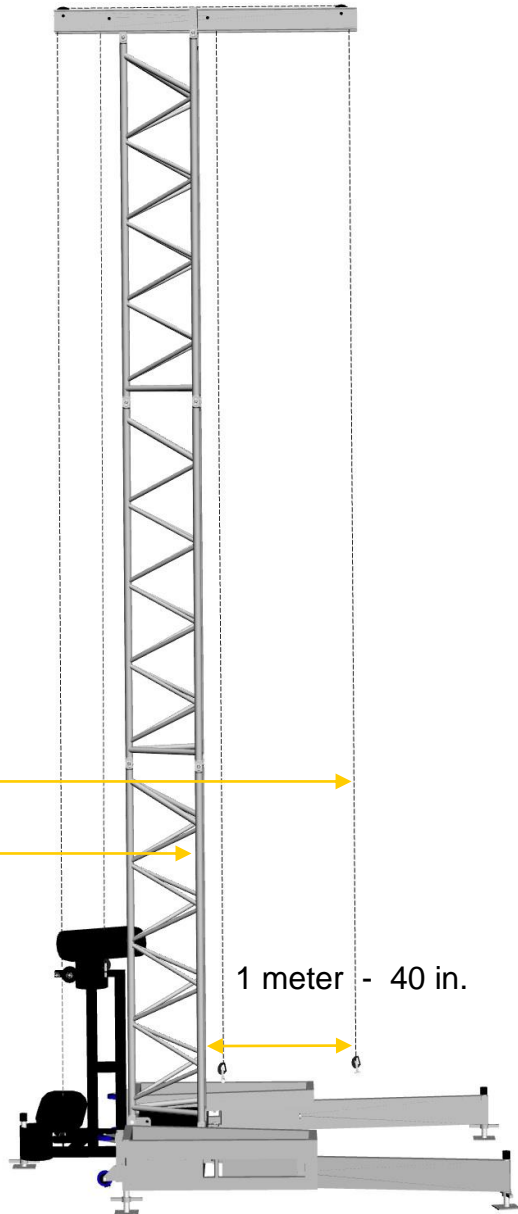

Only combine outer wheels and / or inner wheels of the Top S-60-M2T

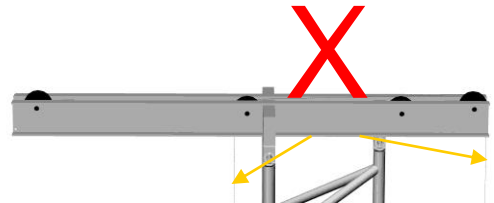
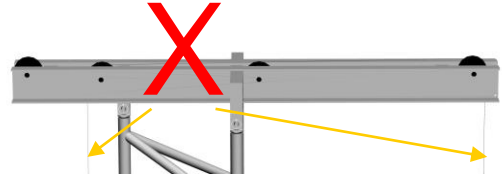
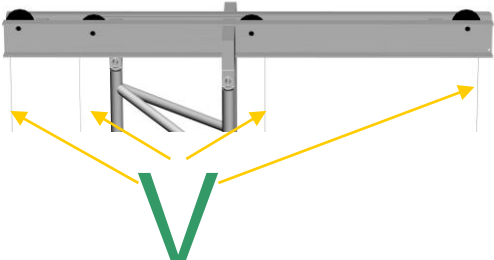

Step 31 :

Fly your line array

The illustration shows the use of both front and rear suspension points

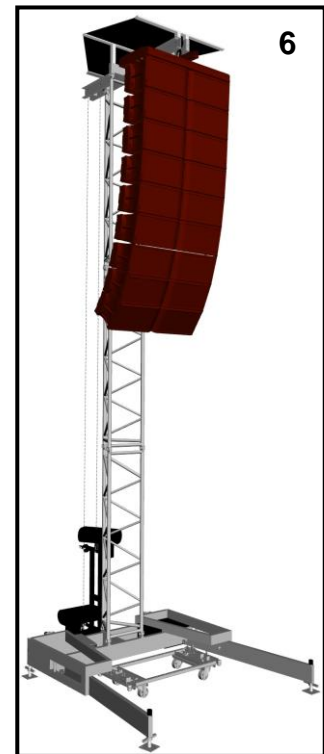
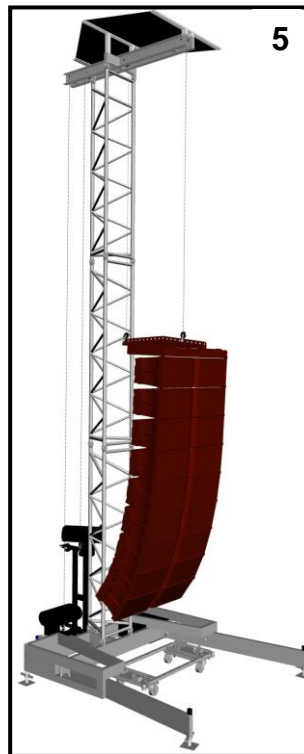
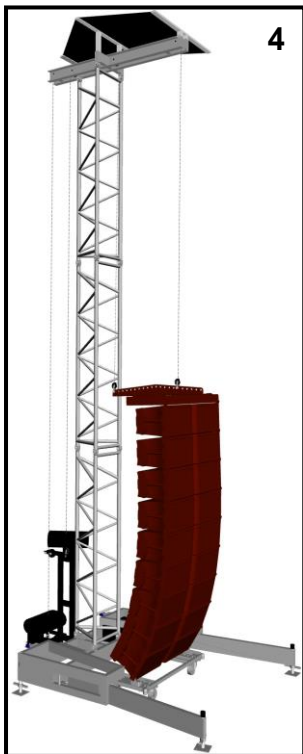
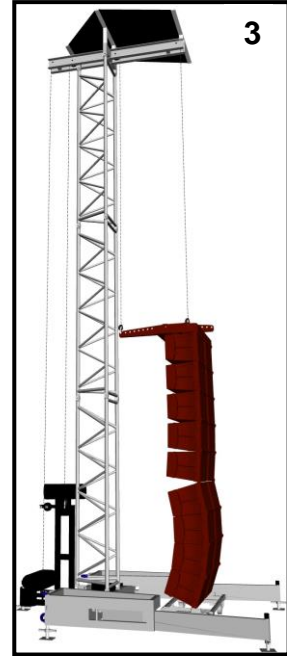
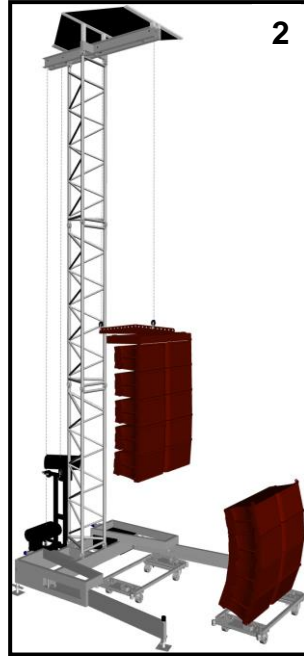
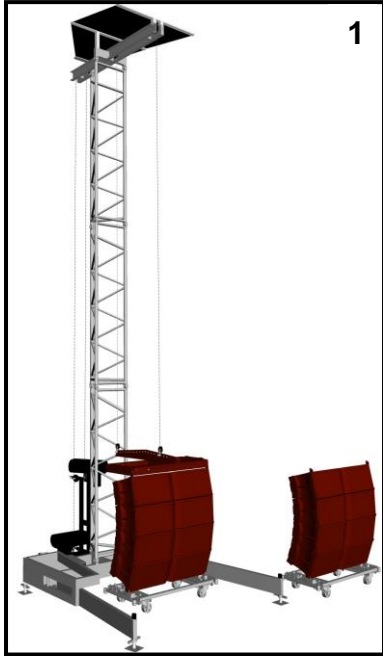

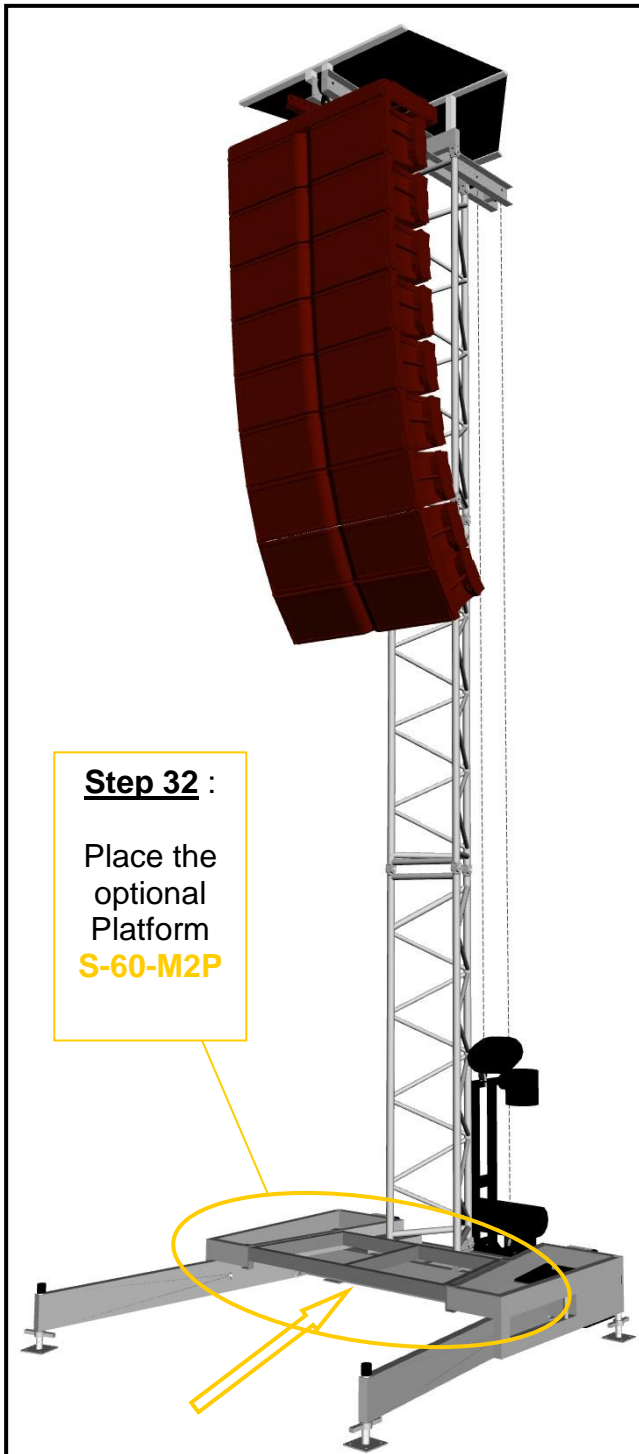

Step 32 :
Place the optional Platform **S-60-M2P**

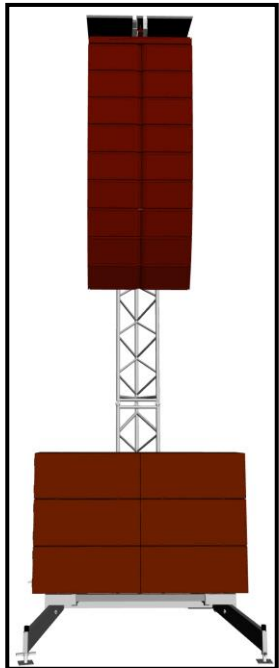
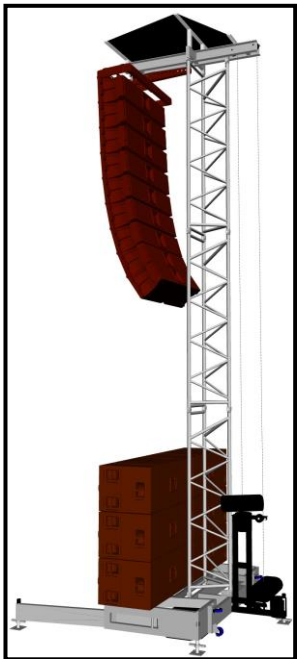

Make sure the **MINI TOWER mk2** mast is perfectly vertical anytime. Check the verticality of the mast after completing the installation of the **MINI TOWER mk2** including the full ballast. If this is **NOT** the case, **one has to correct this by means of the screw jacks !**

The break down of The **MINI TOWER mk2** will be carried out in reverse order, described in the previous paragraphs. **Before the rear pin, with which the mast is connected to the base, is removed, the chain of the chain hoist may only have a slight clearance.**



www.alctruss.com

DISTRIBUTOR

